

Customer/technical services

For any technical or installation queries please contact Vado on 01934 745163.

Guarantee

This product is guaranteed against manufacturing defects from the date of purchase until the expiry of the relevant guarantee period shown below.

The guarantee is only valid if:-

1. The product has been installed, used and maintained in accordance with Vado's instructions and subjected to normal use only.
2. The defect is not due to use of an unsuitable or inadequate water or power supply.
3. The defect is not due to accident, misuse, neglect or repair other than by Vado or Vado authorised agents or damage caused by foreign objects or substances.
4. We have received from you the completed Guarantee Registration Form. Vado accepts no responsibility for any forms lost in the post and returns by registered means is therefore recommended.

Under this guarantee (which is non-transferable) Vado will, at its option, repair or replace free of charge any product (or replacement part) found to be defective. The guarantee does not extend to any consequential loss or damage. After repair or replacement the relevant guarantee period will be calculated from the original date of purchase.

The relevant guarantee periods are:-

1. Twelve years on chrome finish products.
2. Six years on Vado Identity products.
3. Three years on all other products with the exception of Stuart Turner Pumps which carry a 2 year Guarantee on Monsoon Range and 1 Year Guarantee on Showermate Range.

All claims under the guarantee must be submitted in writing to the person who supplied the product to you and must be received no later than the last day of the relevant guarantee period. All claims must be accompanied by proof of purchase (sales receipt or delivery note).

Vado operates a policy of continuous product development and therefore reserves the right to change the product, packaging and documentation specifications without notice.

This guarantee is in addition to and does not affect your statutory rights as a consumer.

Vado

Wedmore Road, Cheddar, Somerset, England BS27 3EB
tel 01934 744466. fax 01934 744345
technical@vado-uk.com
www.vado-uk.com

GUARANTEE REGISTRATION

NAME				
ADDRESS				
	POSTCODE			
RETAILER				
ADDRESS				
	POSTCODE			
PURCHASE DATE	ARTICLE NUMBER	(SEE BOX)		
PRODUCT DESCRIPTION				
WHO INSTALLED THE PRODUCT?	RETAILER	PLUMBER	BUILDER	SELF
FOR VADO USE				



Installation & maintenance instructions

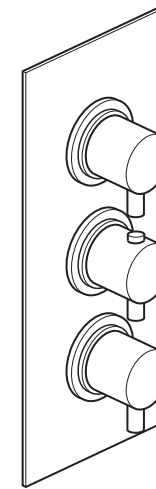

celsius elements mix notion tonic

Concealed 3 handle thermostatic shower valve
with rectangular backplate, 3/4"

Note: For illustrative purposes only a celsius is shown throughout the instruction.
Please follow the same procedure to install all the other shower valves.

Version 1

Please leave these instructions with the customer

Important - please read

Please read these instructions carefully before starting installation and keep for future reference.

Remove all packaging and check the product for missing parts or damage before starting installation.

Any alterations made to this product and fittings may infringe water regulations and will invalidate the guarantee.

The installation must comply with all Local/National Water Supply Authority Regulations/Byelaws and Building and Plumbing Regulations.

We strongly recommend that you use a qualified and registered plumber.

IMPORTANT: Failure to comply with the installation and commissioning instructions as detailed will invalidate the product warranty.

General installation

Thermostatic Valves

This thermostatic mixing valve range of three handled wall mounted shower valves have been specifically designed and manufactured to meet the requirements of BS EN 1111. The valves have been independently tested and approved as a TYPE 2 valve under the TMV scheme.

This mixer valve is suitable for any water system. Where instantaneous heaters are used, the flow of hot water sufficient to start and go on burning must reach the minimum flow required – as specified by the heater manufacturer.

These fittings are mixing devices and therefore water supplies must be reasonably balanced.

Where connections are made to the mains cold water supply, WRC approved single check valves must be fitted to both hot and cold inlets. This is a stated requirement of Water Supply (Water Fittings) Regulations 1999 Schedule 2, Section 15.

Before making any inlet pipe connections, all supply pipes **MUST** be thoroughly flushed to remove debris. Failure to do so could result in damage or low flow from the mixer unit. Water Supply (Water Fittings) Regulations 1999 Schedule 2 Section 13.

The fitting of isolating valves to the inlet feeds is advised for ease of maintenance.

Please take great care when installing this mixer not to damage its surface.

Operating pressures (on hot and cold line) should be kept as balanced as possible in order to assure optimum efficiency.

Note: When pressure is higher than 5 bar a pressure reducer is required to be fitted before the valve.

Please note if installing in an enclosed environment, access should be left for servicing and maintenance. No costs relating to inadequate access can be accepted.

 **Warning!** Please check for any hidden cables and pipes before drilling holes in the wall.

Care of the mixer

Our products are finished to the highest standard and due care needs to be taken to ensure their looks are retained.

We recommend cleaning all products with a soft damp cloth **ONLY** and advise strongly against the use of **ALL** cleaning products i.e. powders and liquids.

If the above instructions are not followed this will invalidate your guarantee in the event of a problem occurring.

Maintenance - continued

2. Remove the handle (see notes on pages 10-11), cover plate ring, cover plate inner ring, temperature valve ring to gain access to the grub screw.
3. Release the grub screw located at the 3 o'clock position, and remove the thermostatic cartridge by unscrewing.
4. Clean the filters by rinsing them in water to remove the dirt and soaking them in vinegar or descaling agent.
5. Before reassembling the cartridge, clean its housing with a wet cloth and grease the 'O' rings using a suitable silicone lubricant. Reassemble the cartridge.
6. Screw the cartridge back into the valve and secure with the grub screw at the 3 o'clock position.
7. Place the plastic stop ring so that the stop is at the 12 o'clock position.
8. Make sure everything is tight and secure, turn on the water supply at the isolating valves.
9. Now check the water temperature to ensure correct calibration (see page 13 for temperature resetting).
10. Replace the 3 rings and the handle.
11. Secure the handle (see notes on pages 12-13).

General installation

Working Parameters And Technical Specification

Factory Temperature Setting	38° C
Temperature Setting Range	35° C to 46° C
Temperature (Hot Supply)	55° C to 65° C
Temperature (Cold Supply)	5° C to 25° C
Minimum Hot To Mix Differential Temperature	10° C
Temperature Stability	±2° C
Working Pressure, Static	10 Bar Max
Working Pressure, Dynamic High Pressure	0.5–5 Bar
Maximum Pressure Loss Ratio	10:1
Flow Rate Minimum	4 L/MIN
Flow Rate @ 1 Bar Pressure Loss	21 L/MIN

NOTES: Designations of use in table, refer to HP-S and HP-T.

Valves operating outside these conditions cannot be guaranteed by the Scheme to operate as Type 2 valves.

If water supply is fed by gravity then supply pressure should be verified to ensure the conditions of use are appropriate for the valve.

Approvals & Application

Building Cert Approval Number BC1391/0514

The thermostatic mixing valve range of three handled wall mounted shower valves have been independently tested by WRC and certified by Buildcert as meeting the requirements of the BS EN1111 specification under the TMV2 scheme as being suitable for use on the following designations.

Code	Operating Pressure	Application
HP-S	High Pressure	Shower – temperature 41° C
HP-T	High Pressure	Tub/Bath – temperature 46° C

Operating specifications

Hot Water Supply Temperature:

Maximum: 80° C

Minimum: 10° C higher than the maximum required mixed temperature (advise 65° C)

Operating Pressure

Maximum: 5 bar

Minimum: 0.2 bar

flow rate

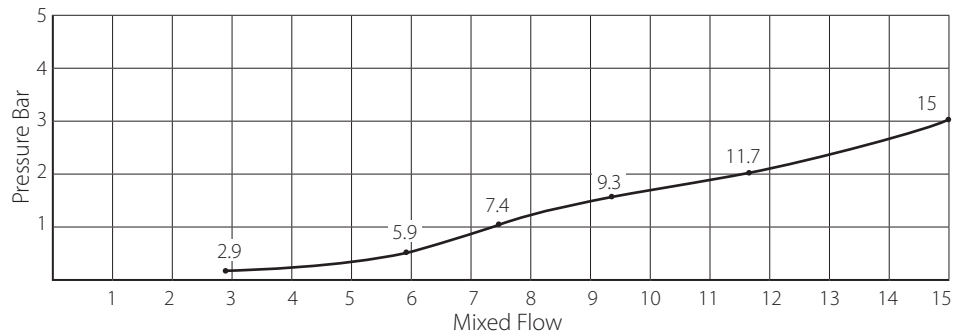

Flow rate curve is for reference only. The actual pressure drop may vary depending on system temperature and pressure.

Recommended outlet temperatures

The BuildCert TMV scheme recommends the following mixed water outlet temperature for use in all premises:

44° C for bath fill but see notes below;

41° C for showers;

The mixed water temperatures must never exceed 46° C.

The maximum mixed water temperature can be 2° C above the recommended maximum set outlet temperature.

Note:

46° C is the maximum mixed water temperature from the bath tap. The maximum temperature takes account of the allowable temperature tolerances inherent in thermostatic mixing valves and temperature losses in metal baths.

It is not a safe bathing temperature for adults or children.

The British Burns Association recommends 37° to 37.5° C as a comfortable bathing temperature for children. In premises covered by the Care Standards ACT 2000, The maximum mixed water outlet temperature is 42° C.

Maintenance

We advise that the below is carried out annually as failure to do so may result in invalidation of warranty.

Shut off the water supply to both hot and cold inlets, before commencing any maintenance work below.

IMPORTANT:

Please see the below procedure for isolating concealed thermostatic valves.

1. Remove handles/faceplate and trim parts allowing access to the isolation points on the valve.
2. Screw down the isolation screws clockwise until you feel a resistance (taking care not to over tighten).
3. Turn shower on to check isolation, please ensure that your body/hands are not under the flow of water as there is a potential for delivery of hot water.
4. Remove temperature stop ring (essential).
5. With shower in the on position, replace temperature handle on thermostatic valve (ensure temperature stop ring has been removed).
6. Turn temp handle fully anti clockwise until stop point is reached and can be turned no further, please ensure that your body/hands are not under the flow of water as there is potential for delivery of hot water if isolation has been unsuccessful.
7. Turn temperature handle fully clockwise until you feel a click.
8. If there is no flow of water coming from the outlet during both points 6 and 7 isolation has been successful, you may now remove and maintain the cartridge.
9. If at any of the above points water continues to flow please isolate at an alternative point within the system for both hot and cold and repeat points 3-9.

This thermostatic valve is fitted with a single filtering facility. Filters are fitted on the thermostatic cartridge.

Depending on the water quality, filters may become dirty, causing reduced flow and inefficient working of the valve.

Non return valves.

Undo both hex nuts each side of the cartridge using a 27mm box spanner. Pull out the non return valve, rinse in water to remove the dirt, and then soak them in vinegar or descaling agent. Grease the 'O' rings using a suitable silicone lubricant and replace.

Cartridge Filters

To clean the filters, you must first remove the cartridge from the housing.

Removing the Cartridge

1. Shut off the water supply to both inlets at the isolating valves.

Commissioning

Commissioning notes for Thermostatic Mixing Valves.

The first step in commissioning a thermostatic mixing valve is to check the following:

1. The designation of the thermostatic mixing valve matches the application.
2. The supply pressures are within the valves operating range.
3. The supply temperature are within the valves operating range.
4. Isolating valves (and strainers preferred) are provided.

If all these conditions are met, proceed to set the temperature as stipulated in the manufacturer installation instructions.

It is a requirement that all TMV2 approved valves shall be verified against the original set temperature results once a year. When commissioning/testing is due the following performance checks shall be carried out.

Measure the mixed water temperature at the outlet.

Carry out the cold water supply isolation test by isolating the cold water supply to the TMV, wait for five seconds if water is still flowing check that the temperature is below 46°C.

If there is no significant change to the set outlet temperature ($\pm 2^{\circ}\text{C}$ or less change from the original settings) and the fail-safe shut off is functioning, then the valve is working correctly and no further service work is required.

Notes

If there is a residual flow during the commissioning or the annual verification (cold water supply isolation test), then this is acceptable providing the temperature of the water seeping from the valve is no more than 2°C above the designed maximum mixed water outlet temperature setting of the valve.

Temperature readings should be taken at the normal flow rate after allowing for the system to stabilise.

The sensing part of the thermostatic probe must be fully submerged in the water that is to be tested.

Any TMV that has been adjusted or serviced must be re-commissioned and re-tested in accordance with the manufacturer's instructions.

The installation of thermostatic mixing valves must comply with the requirements of the Water Supply (Water Fittings) Regulations 1999.

Dimensions

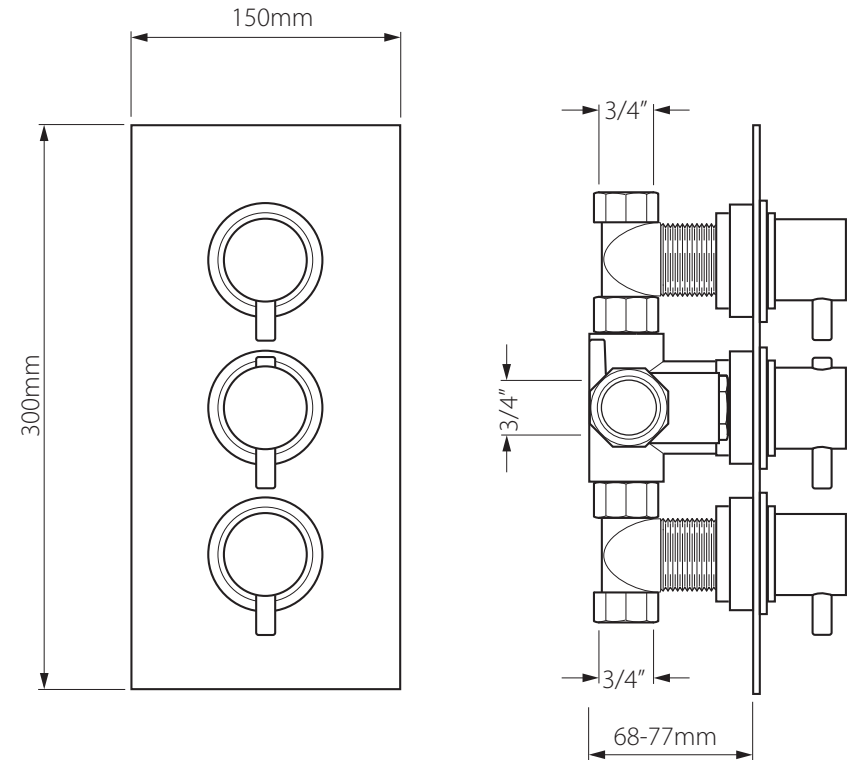

Please Note: If using optional extension shrouds the MIN - MAX depth dimensions become: 77mm - 103mm.

To calculate the depth of your shower valve see the shower depth calculator on page 4.

Operating Specifications

Hot Water Supply Temperature:

Maximum: 80° C

Minimum: 10° C higher than the maximum required mixed temperature (advise 65° C)

Operating Pressure

Maximum: 5 bar

Minimum: 0.2 bar

Shower valve depth calculator

This guide shows how to calculate the depth that your VADO shower valve should be set in the wall to create optimum performance and appearance.

valve	min-max wall mount (standard) (mm)	optimum installation depth (standard) (mm)	min-max wall mount with extension option (mm)	optimum installation depth with extension option (mm)	extension option (both items needed, NB: total of 3 items for 3 handle valves)
NOT-128C-3/4-C/P	68-77	73	77-103	90	X1 NOT-148C/TEMP-EXT & X2 NOT-148/FLOW-EXT
MIX-128C-3/4-C/P	68-77	73	77-103	90	X1 CEL-148C/TEMP-EXT & X2 CEL-148/FLOW-EXT
ELE-128C-3/4-C/P	68-77	73	77-103	90	X1 CEL-148C/TEMP-EXT & X2 CEL-148/FLOW-EXT
CEL-128C/SQ-3/4-C/P	68-77	73	77-103	90	X1 CEL-148C/TEMP-EXT & X2 CEL-148/FLOW-EXT
TON-128C-3/4-C/P	68-77	73	77-103	90	X1 CEL-148C/TEMP-EXT & X2 CEL-148/FLOW-EXT

Temperature resetting

Note: mixed water temperature at terminal fitting should never exceed 46°C.

The valve has been factory set under balance pressures and hot water supply at 65°C. When your specific operating conditions are significantly different from the above, the temperature of the water may vary from the setting.

When the difference is too great, you can adjust the calibration of the valve to suit individual requirements of the installation:

1. Select 38° C or the arrow on the handle and check the temperature of the water being delivered to the outlet with a thermometer.

2. If the temperature is unacceptable proceed to reset the calibration as follows:

Remove the handle (see notes on pages 12-13). Do not remove the plastic stop ring. Turn the spline of the valve clockwise to decrease the temperature and anti-clockwise to increase the temperature until 38° is achieved at outlet.

3. Ensure that the stop on the stop ring is at 12 o'clock and replace the handle with the temperature override button also pointing at 12 o'clock being careful not to turn the spline of the valve, replace the handle (see notes on pages 12-13).

Your valve setting is now calibrated.

Operation

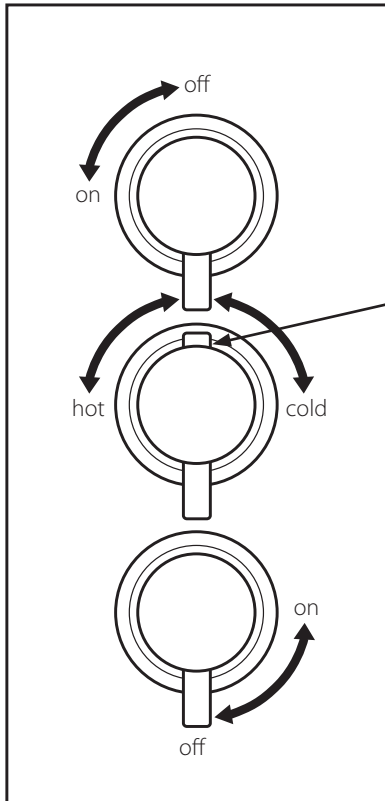

Moving the top lever controls the flow of water to the top outlet.

Push down on the button to override the set temperature.

Moving the middle lever anti-clockwise will increase the water temperature.

Moving the lower lever controls the flow of water to the bottom outlet.

Shower valve depth calculator

STEP 1

Identify the optimum installation depth (X). Please look up optimum depth for your chosen shower valve on the opposite page, or you can access the same information on our website at www.vado-uk.com. This is represented as X in fig 1.

STEP 2

Calculate the thickness of the finished tile wall (T). This is the total thickness of your tile plus adhesive plus plasterboard or ply cladding. This is shown as T in fig 2.

Calculation:

$T = A$ (tile thickness) + B (adhesive thickness, usually 3-5mm) + C (plasterboard or ply cladding thickness).

Example:

If working with a 10mm thick tile, 5mm layer of adhesive, 15mm thick plasterboard
 $T = 10\text{mm} + 5\text{mm} + 15\text{mm} = 30\text{mm}$.
 T value is therefore 30mm.

STEP 3

Calculate the depth that you need to fit your valve (D). This depth is the total distance from the front face of the studwall to the back of the shower valve (or front face of your VADO WG-STUDFAST bracket if you are using the VADO studfast bracket for easier installation). This is shown as D in fig 2.

Calculation: $X - T = D$

Example:

If fitting a NOT-128C-3/4-C/P the optimum depth (X) is 73mm.
 In step 2, T was identified as 30mm.
 D is calculated as: $73\text{mm} - 30\text{mm} = 43\text{mm}$.
 Therefore you install the valve at a distance of 43mm from the front face of your timber or metal stud wall to the back of the shower valve (or front face of your studfast bracket).

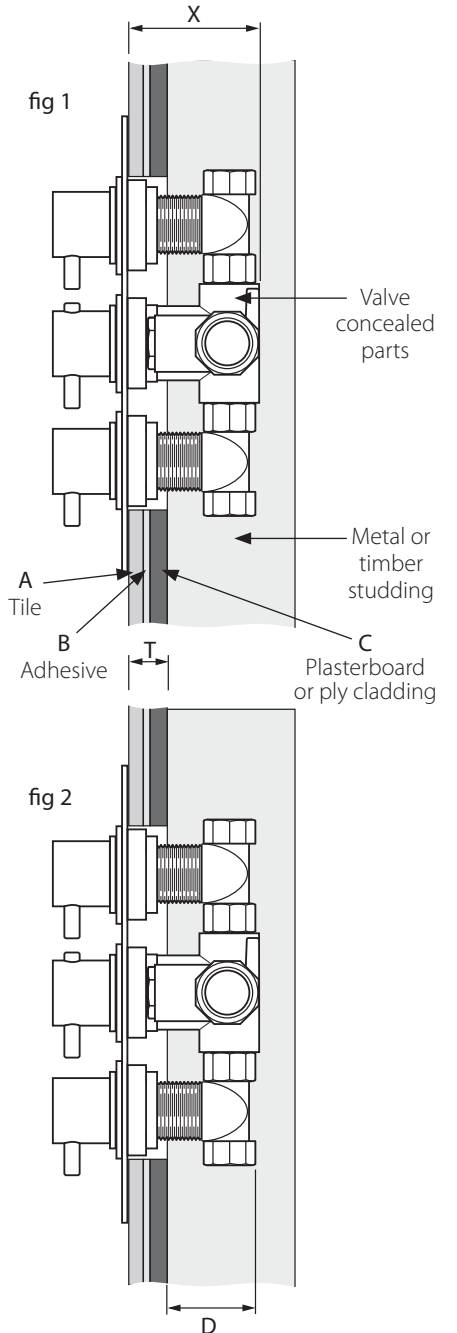

Installation - standard fixing

Before installing the Vado thermostatic mixing valve range of three handled wall mounted shower valve, ensure that the designation of the valve matches the application, flow rates, dynamic pressures and temperatures must be within the limits stated.

The Thermostatic mixing valve must be installed in such a position that maintenance of the TMV and its valves and the commissioning and testing of the TMV can be undertaken.

The fitting of isolation valves is required as close as is practicable to the water supply inlets of the TMV.

The Valve should not be installed until the system has been flushed until free of all debris. Once this is done, the fitting of strainers is recommended.

The Thermostatic Mixing Valve contains temperature sensitive components. Soldering near the union adaptors or main valve body must be avoided.

The installation of Thermostatic mixing valves must comply with the requirements of the Water Supply (Water Fittings) Regulations 1999.

Rinse pipeworks carefully for a long while before fitting the valve: do not allow dirt, metal particles or shavings to block the filters fitted on inlets.

Turn off the water supply.

Please note: That access must be left to the thermostatic cartridge grub screw located at the 3 o'clock position in order to release the cartridge for maintenance at a later stage.

Please ensure that sufficient access is left between the tile cut out to the non return valve housing and isolation point, in order to carry out maintenance when necessary.

The valve must be set into the wall between (68mm minimum – 77mm maximum)

If you are fitting the valve to a partition wall or a wall of particularly soft substrate you will need specialist fixings.

Select the position for the shower valve and offer the shower valve to the wall, mark the 2 fixing points with a suitable pencil. Remove the shower valve from the wall, drill the holes to a suitable depth for the wall plugs and secure with suitable screws.

During and after installation protect the outer parts by leaving the plastic sleeve on the valve to avoid damage to plated surfaces.

Connect hot supply to left inlet of the valve and cold supply to right inlet.

Connect the shower to the top outlet, bath or other desired installation setup i.e. body tiles to the bottom outlet.

Screw the flow valve rings onto the top and bottom valves, and the temperature valve ring onto the middle valve, screw on all three cover plate inner rings.

Slide the cover plate over the valve and secure to the wall with the three cover plate rings, apply a thin bead of silicone around the outside to seal against the tiled surface.

Shower flow control handle (top).

(see pages 12 and 13 for installation of handles for your model).

Temperature control handle (middle).

Push on the stop ring with the stop at 12 o'clock (see pages 12 and 13 for installation of handles for your model).

Bottom outlet flow control handle (bottom).

(see pages 12 and 13 for installation of handles for your model).

Installation - handles

tonic

Flow control handles

(top and bottom).
Carefully slide the flow control handle onto the splines of the top valve and secure in position with the grub screw on the underside.



Temperature control handle

(middle).
With the temperature override button pointing at 12 o'clock, press down on the button and push the handle onto the splines, being careful not to turn the spline of the valve, secure in position with the grub screw on the underside.

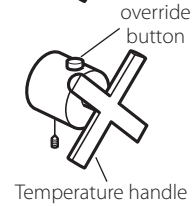

Ensure the plastic spacer ring is firmly positioned inside the handle before installation.

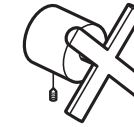

Installation - handles

notion

Flow control handles

(top and bottom). Carefully slide the flow control handle onto the splines of the top valve and secure in position with the grub screw on the side.



Temperature control handle (middle).

Carefully slide the temperature control handle onto the splines and secure in position with the grub screw on the side.

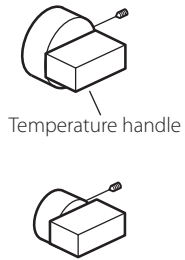

elements

Flow control handles

(top and bottom). Carefully slide the flow control handle onto the splines of the adapter, with the lever at 12 o'clock (248 only), secure the handle with the grub screw on the underside.

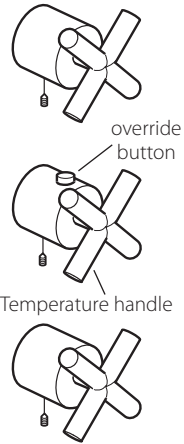

Temperature control handle (middle).

With the temperature override button pointing at 12 o'clock, press down on the button and push the handle onto the splines, being careful not to turn the spline of the valve, secure in position with the grub screw on the underside. Ensure the plastic spacer ring is firmly positioned inside the handle before installation.

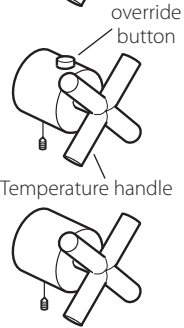

mix

Flow control handles

(top and bottom). Carefully slide the flow control handle onto the splines of the top valve and secure in position with the grub screw on the underside.

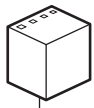

Temperature control handle (middle).

With the temperature override button pointing at 12 o'clock, press down on the button and push the handle onto the splines, being careful not to turn the spline of the valve, secure in position with the grub screw on the underside.

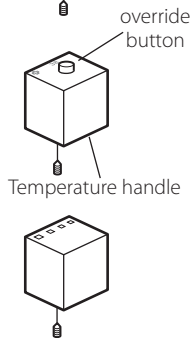

celsius

Flow control handles

(top and bottom). Carefully slide the flow control handle onto the splines of the valve, with the lever at 6 o'clock, secure the handle with the grub screw on the top.

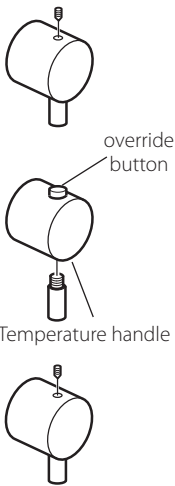

Temperature control handle (middle).

Remove the lever from the temperature control handle by unscrewing (grub screw underneath), With the temperature override button at 12 o'clock, press down on the button and push the handle onto the splines, being careful not to turn the spline of the valve, secure the grub screw and replace the lever. Ensure the plastic spacer ring is firmly positioned inside the handle before installation.

Installation - standard fixing

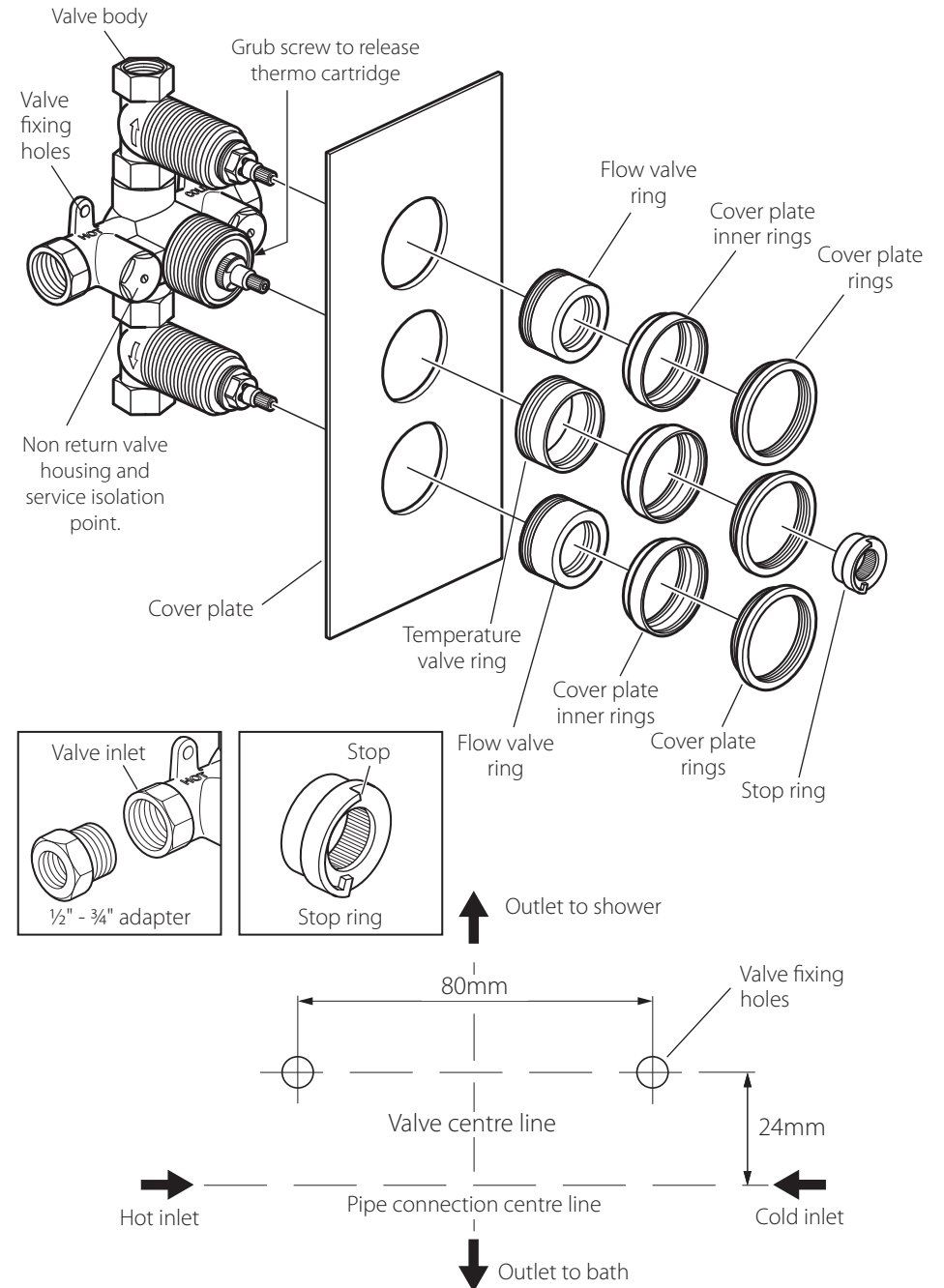

Installation - extended fixing (optional)

Before installing the Vado thermostatic mixing valve range of three handled wall mounted shower valve, ensure that the designation of the valve matches the application, flow rates, dynamic pressures and temperatures must be within the limits stated.

The Thermostatic mixing valve must be installed in such a position that maintenance of the TMV and its valves and the commissioning and testing of the TMV can be undertaken.

The fitting of isolation valves is required as close as is practicable to the water supply inlets of the TMV.

The Valve should not be installed until the system has been flushed until free of all debris. Once this is done, the fitting of strainers is recommended.

The Thermostatic Mixing Valve contains temperature sensitive components. Soldering near the union adaptors or main valve body must be avoided.

The installation of Thermostatic mixing valves must comply with the requirements of the Water Supply (Water Fittings) Regulations 1999.

Rinse pipework carefully for a long while before fitting the valve: do not allow dirt, metal particles or shavings to block the filters fitted on inlets.

Turn off the water supply.

Please note: That access must be left to the thermostatic cartridge grub screw located at the 3 o'clock position in order to release the cartridge for maintenance at a later stage.

Please ensure that sufficient access is left between the tile cut out to the non return valve housing and isolation point, in order to carry out maintenance when necessary.

The valve must be set into the wall between (77mm minimum – 103mm maximum)

If you are fitting the valve to a partition wall or a wall of particularly soft substrate you will need specialist fixings.

Select the position for the shower valve and offer the shower valve to the wall, mark the 2 fixing points with a suitable pencil. Remove the shower valve from the wall, drill the holes to a suitable depth for the wall plugs and secure with suitable screws.

During and after installation protect the outer parts by leaving the plastic sleeve on the valve to avoid damage to plated surfaces.

Connect hot supply to left inlet of the valve and cold supply to right inlet.

Connect the shower to the top outlet, bath or other desired installation setup i.e. bodytiles to the bottom outlet.

Screw the flow valve rings onto the top and bottom valves, and the temperature valve ring onto the middle valve, screw on all three cover plate inner rings.

Slide the cover plate over the valve and secure to the wall with the three cover plate rings, apply a thin bead of silicone around the outside to seal against the tiled surface.

Shower flow control handle (top).

Slide the spline adapter onto the splines on the valve and secure in position with the screw (see pages 12 and 13 for installation of handles for your model).

Temperature control handle (middle).

Slide the spline adapter onto the splines on the valve and secure in position with the screw. Push on the stop ring with the stop at 12 o'clock (see pages 12 and 13 for installation of handles for your model).

Bottom outlet flow control handle (bottom).

Slide the spline adapter onto the splines on the valve and secure in position with the screw (see pages 12 and 13 for installation of handles for your model).

Installation - extended fixing (optional)

